

MACHINE-LAY Installation Manual

PaveDrain® Installation Manual

Table of Contents

<u>Section 1:</u>	Base Preparation (pages 3 – 6)
<u>Section 2:</u>	Machine-Lay PaveDrain Blocks (pages 8 – 11)
<u>Section 3:</u>	Edge Restraints (pages 12 – 15)
<u>Section 4:</u>	PaveDrain End Block (page 15)
<u>Section 5:</u>	Finishing the PaveDrain System (page 16)

The Confidential Information to be disclosed can be described as and includes:

Invention description(s), technical and business information relating to proprietary ideas and inventions, ideas, patentable ideas, trade secrets, drawings and/or illustrations, patent searches, existing and/or contemplated products and services, research and development, production, costs, profit and margin information, finances and financial projections, customers, clients, marketing, and current or future business plans and models, regardless of whether such information is designated as “Confidential Information” at the time of its disclosure.

2. The Recipient agrees not to disclose the confidential information obtained from the discloser to anyone unless required to do so by law.

3. This Agreement states the entire agreement between the parties concerning the disclosure of Confidential Information. Any addition or modification to this Agreement must be made in writing and signed by the parties.

4. If any of the provisions of this Agreement are found to be unenforceable, the remainder shall be enforced as fully as possible and the unenforceable provision(s) shall be deemed modified to the limited extent required to permit enforcement of the Agreement as a whole.

Section 1

Base Preparation

Open Graded Base & Bedding Course Aggregate: If more than 6" of base stone is required, only the top 4-6" shall be Typ. AASHTO/ASTM #57 Stone bedding layer (*clean, angular on all sides, no fines*). The final depth to be determined by Engineer. This layer is used as a leveling/bedding course directly beneath the blocks (see Fig. 1). Additional stone depth should consist of either AASHTO/ASTM #2 or #3 stone (*clean, angular on all sides, no fines*). The final depth to be determined by Engineer.

Edge Restraint: Defining the edges of the PaveDrain system is important (see examples on page 12). Concrete curbing is the most commonly used material. However, using other materials such as plastic strip edging (commonly used in typical pavers) is not advisable.

Separation Fabric: A high strength woven monofilament or multi-filament geotextile is highly recommended to be installed as a base reinforcement and separation layer between the aggregate storage bedding layer (depth to be determined) and the native sub-grade. Please check with your local PaveDrain representative to determine the appropriate geosynthetic required. The geosynthetic is a key component of the PaveDrain system. Negating its use could be detrimental to the function, performance and life cycle of the PaveDrain system. The "vertical walls" of your prepared area should also be lined with an appropriate geosynthetic to prevent soil and aggregate migration (see Fig. 2, 3 & 4).

Fig. 1



Fig. 2



LAYOUT & PREPARATION

If machine-lay units are to be installed, they will arrive wrapped on pallets. Pallets will weigh approximately 4,000 lbs or less. These units will be interlocked to work in conjunction with the hydraulic clamp (see pages 8 & 9 for pallet and equipment). **Please make sure to print out the approved layout drawings on the large jobsite engineer sized paper. It is crucial to see where all the required block are to be laid within the approved area of coverage.**

NOTE: Before digging, always call your local utility companies to locate any underground utilities.

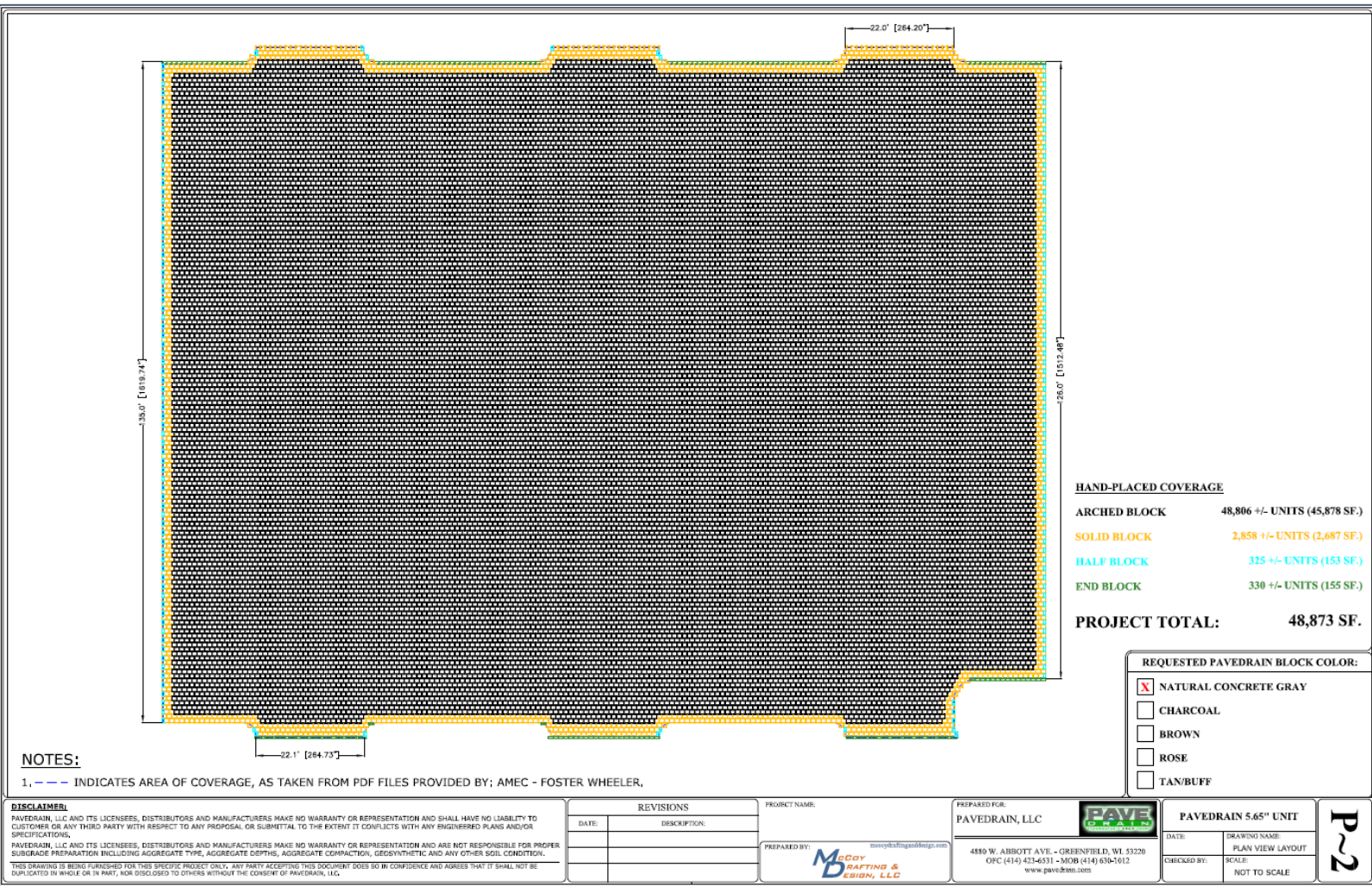

PREPARE SUBGRADE SOILS

For best results, the finished subgrade should be flat, smooth and stable. A California Bearing Ratio (CBR) should be established well in advance of the installation. The appropriate geosynthetic is critical and should prevent rutting. If the subgrade appears weak or damp following the installation of the appropriate geosynthetic contact a professional geotechnical engineer or local PaveDrain representative for further assistance.

Fig. 3



Fig. 4



PREPARATION OF OPEN GRADED BASE

The depth of stone should be determined well in advance of the installation of the PaveDrain system by the engineer of record, based on the CBR and storm water storage requirements.

Open graded base materials **must** be free of fines. Take care not to track soil onto the geosynthetic or allow sediment to wash into the excavation during construction.

Typ. #57 stone is recommended as the bedding layer of stone (see description below). Place the stone on the appropriate geosynthetic in 4-6" lifts and compact with a vibratory roller. **The use of a vibratory plate compactor in both directions is best for final compaction of the bedding layer of AASHTO #57 stone that will be in direct contact with the bottom of the PaveDrain units unless the optional geogrid is used** (see FIG. 5 on next page). There should be **no visible movement of the material once compacted and the base should be smooth** when completed.

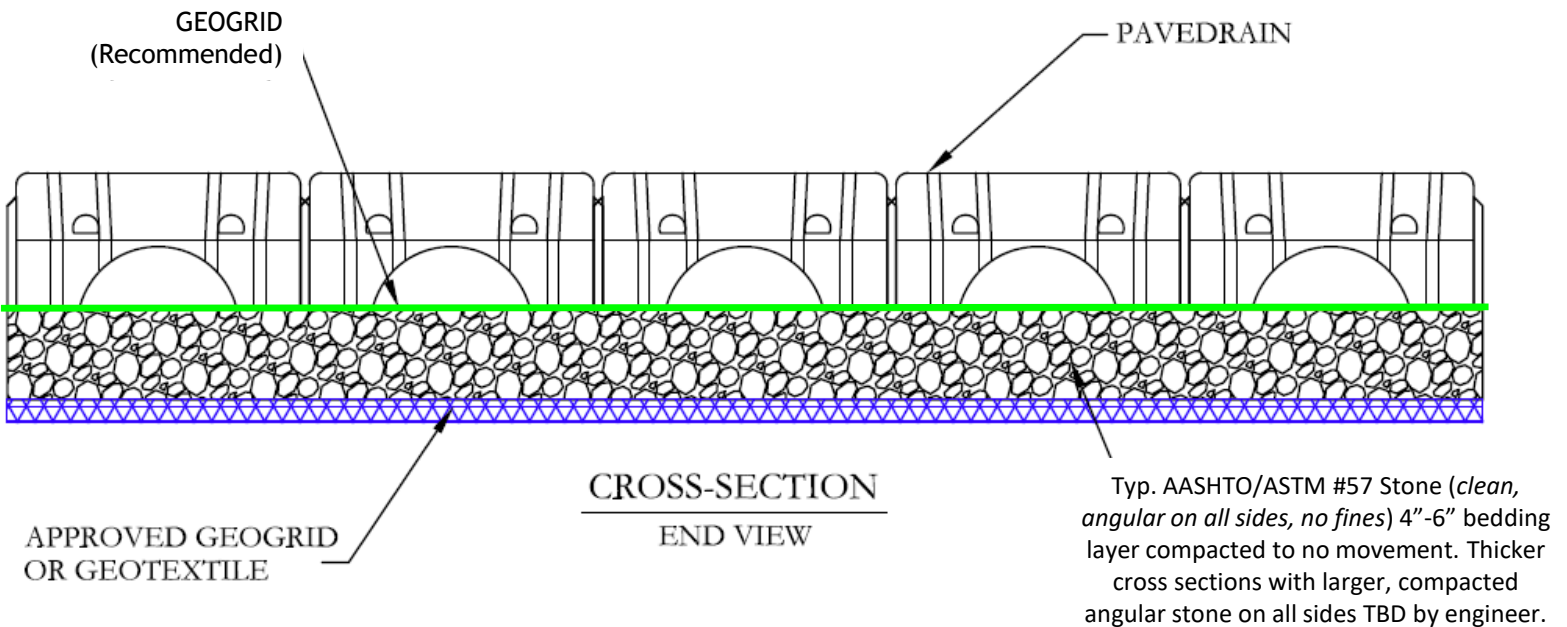

REMEMBER: Subgrade preparation is **CRITICAL!** The PaveDrain system will mirror any grade changes or discrepancies made with the subgrade.

Fig. 5



If it is determined by the engineer of record that a rock depth in excess of 12" is required, then the cross-section below should be followed.

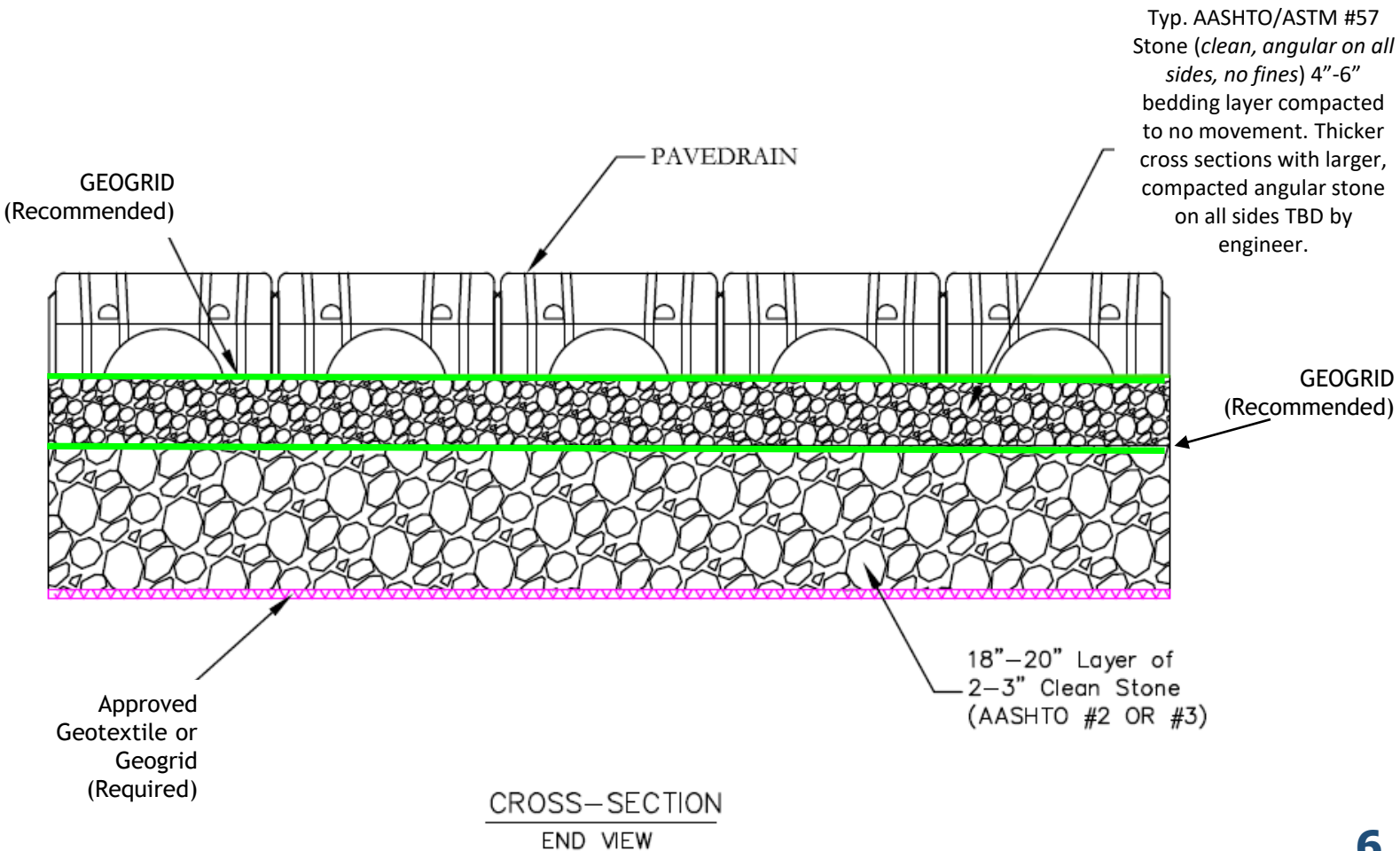

CRUCIAL TOOLS

Professional survey equipment is always recommended; other suggested materials are pipe lasers (if available), marking paint, tape measure, chalk line, block markers/crayons, string line, survey stakes, rubber mallets, 4'-5' pry bars, 4 1/2" angle grinder with concrete cutting blade, masonry saw (wet/dry) with diamond cutting blade, spade and flat shovel, hard-tooth garden rake, Geosynthetic, "peanut" or double roller and plate compactor.

The PaverMax Hydraulic Clamp is required for this type of installation. You can contact your nearest hardscapes installer to see if they own a clamp and machine.

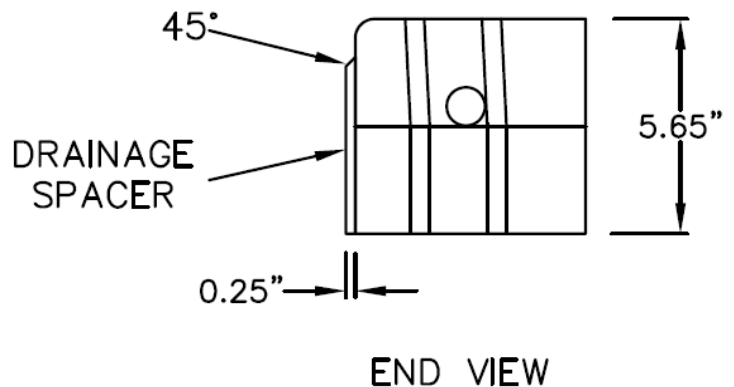
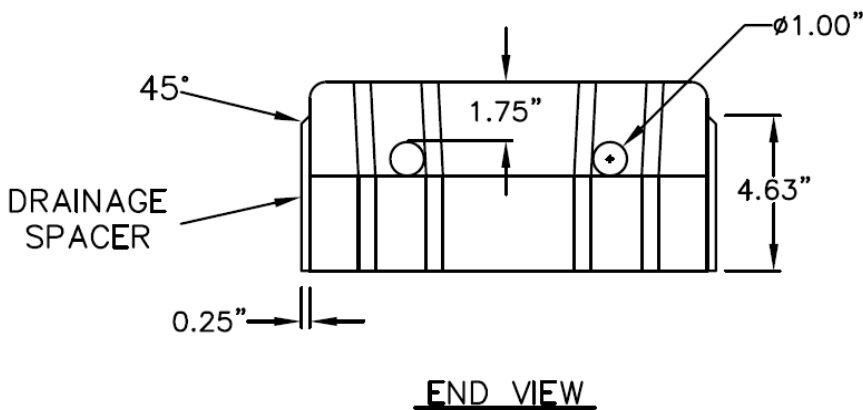
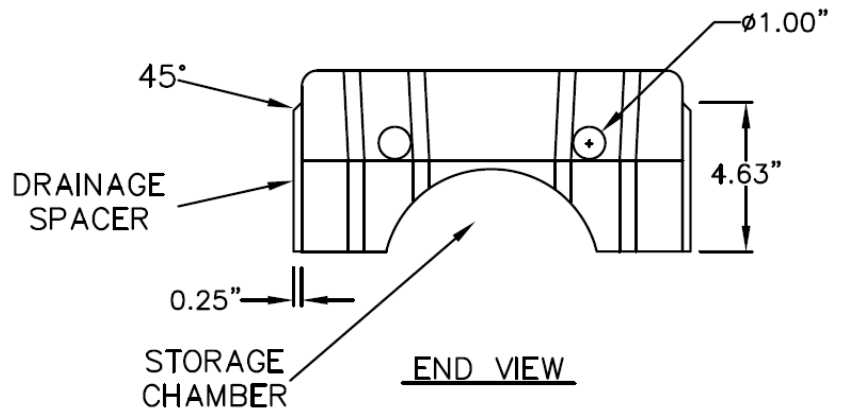

Section 2

Machine-Lay of PaveDrain Blocks

Machine-Lay of PaveDrain units is an option when your project poses certain problems, such as low over-head power/telephone lines, tight areas between buildings, and any other area you cannot operate a crane or excavator to install mats or hand-place individual blocks due to the overall size of the area. The most common pieces of equipment used on Machine-Lay Installation Projects are the **Probst PaverMax machine with a hydraulic clamp (see Fig. 6)** or a **Mini-Excavator with a hydraulic clamp (see Fig. 7)**.

This method of installation typically requires a foreman (with minimal experience and/or minimal training of the PaveDrain system) and 3 general laborers. The 4 man crew will be able to install roughly 3,500 – 5,000 SF per day depending on how many hydraulic installation clamps are used. The amount of SF they install will increase as their experience grows. The foreman will be able to operate any of the necessary equipment (i.e. PaverMax or mini-excavator with hydraulic clamp, forklift or bobcat), while directing the laborers. This type of installation can be used on almost any size PaveDrain project from 7,500 – 100,000 SF.

Fig. 6



Fig. 7



Probst PaverMax Machine with Clamp or Mini-Excavator with Clamp can be used to install.

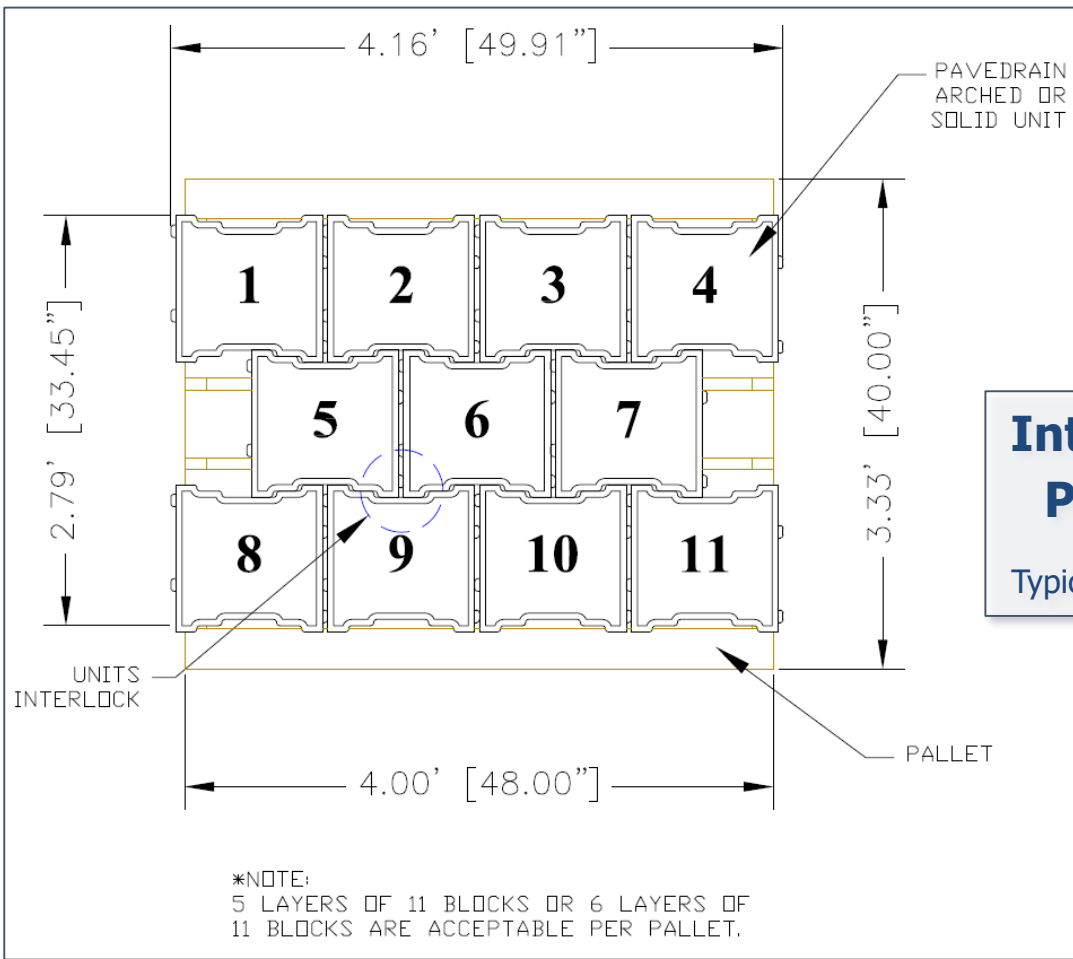

**Interlocked PaveDrain
Pallet configuration**

Typically has 55 to 66 block per pallet.

Step #1: If existing hardscapes are to remain (i.e. asphalt or concrete) the prepared area needs to be 3" (three inches) larger than the area receiving the individual units. In some applications, a concrete collar can be poured before the units are installed (see Fig. 8 & 9 below). **However, we always recommend installing the PaveDrain block before any other perimeter restraints are installed. Doing so reduces the number of block that would need to be cut (see pages 13,14 & 15 for the Two Stage Curb).**

Fig. 8



Fig. 9

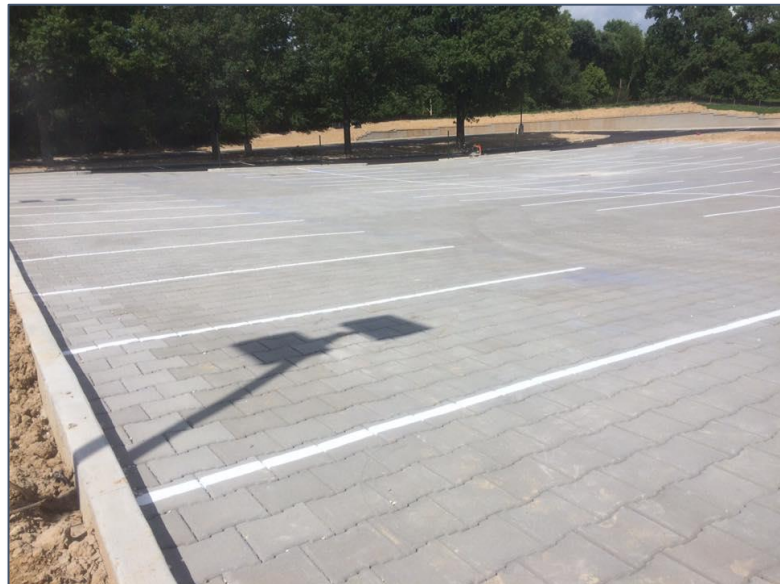

Step #2:

Base preparation is CRITICAL!!!

Undulations and grade changes in the rock base will be reflected in the PaveDrain system. A plate compactor is the best way to level and flatten the base rock before and during installation (See Fig. 5 on page 6). A well prepared rock base is shown in Figures 10 and 11 below.

Fig. 10



Fig. 11



Step #3: **STARTING POINT.** It is beneficial to take the entire area into consideration and lay your first unit in the middle or in one corner. String lines will help facilitate your placement. If you decide to place your first unit in the middle, you must mark that unit with a "+". Then use your string lines to find the exact middle of your open area. Place the unit with the "+" under the intersection of your string lines and you are ready to begin (see Fig. 12). If you start in one corner, you want to use your string line to make an exact 90° corner where you will lay your first unit (see Fig. 13).

Fig. 12



Fig. 13



Step #4: Keep the units tight during installation and follow the string lines. Rubber mallets can help you "seat" the units after they are placed (SEE Fig. 14 & 15).

Fig. 14

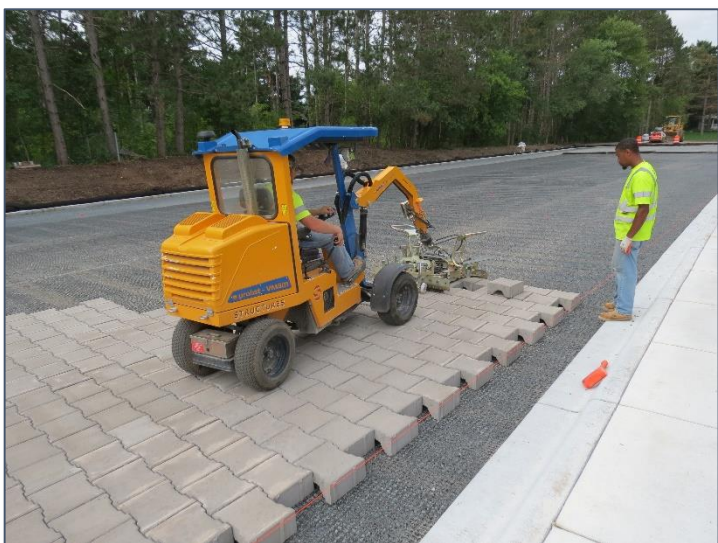

Fig. 15



NOTE: *Foot traffic should be kept to a minimum on the rock. If the rock is compacted correctly, little movement should be apparent once stepped on. Use the plate compactor to fix any major damage.*

Step #5: The individual PaveDrain units can be cut or tailored to accommodate a variety of different shaped working areas or obstacles. Using a concrete block masonry saw with a diamond tipped blade will allow you to custom fit your site (see Fig. 16 & 17).

Fig. 16



Fig. 17



Section 3

Edge Restraints

Edge restraints are used to delineate and confine a PaveDrain system and are highly recommended whenever vehicular loads are present. There are many acceptable options for edge restraints with the PaveDrain System. The detail below and at the top of page 13 show the most common methods utilizing a poured-in-place concrete flush curb. If you wish to consider other alternates, please contact your local sales representative for support.

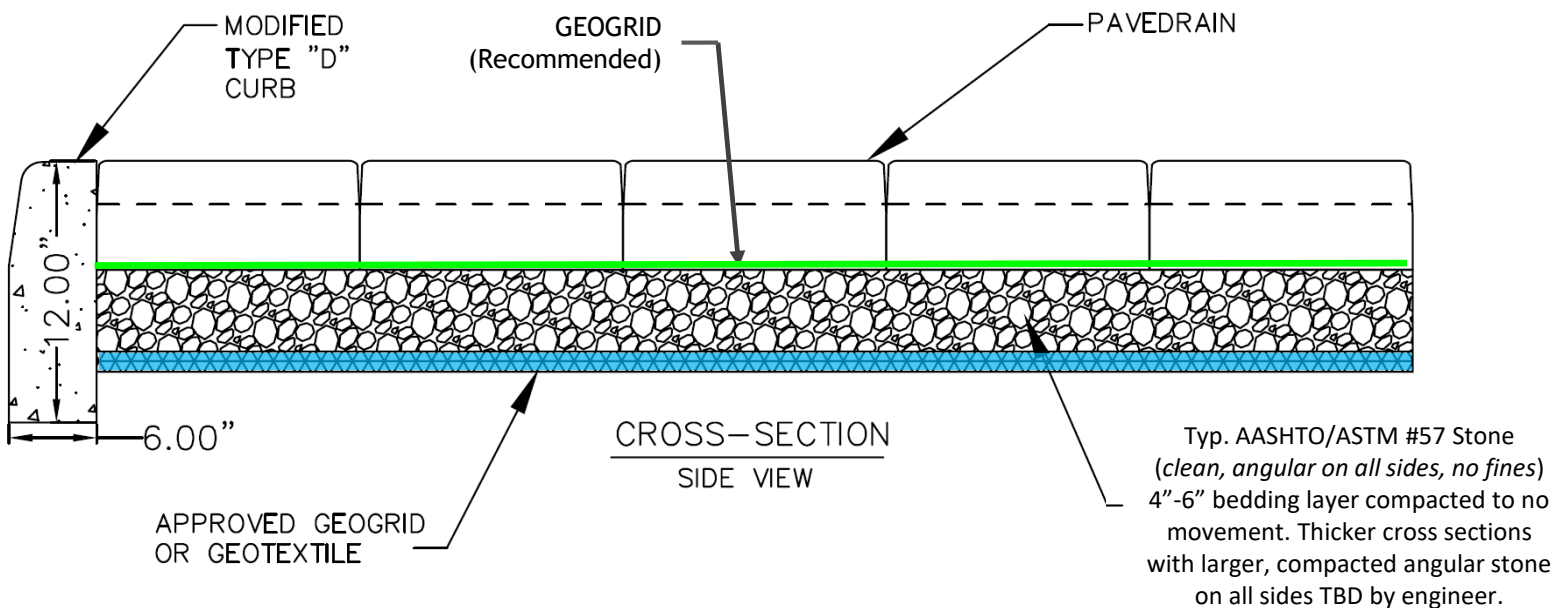

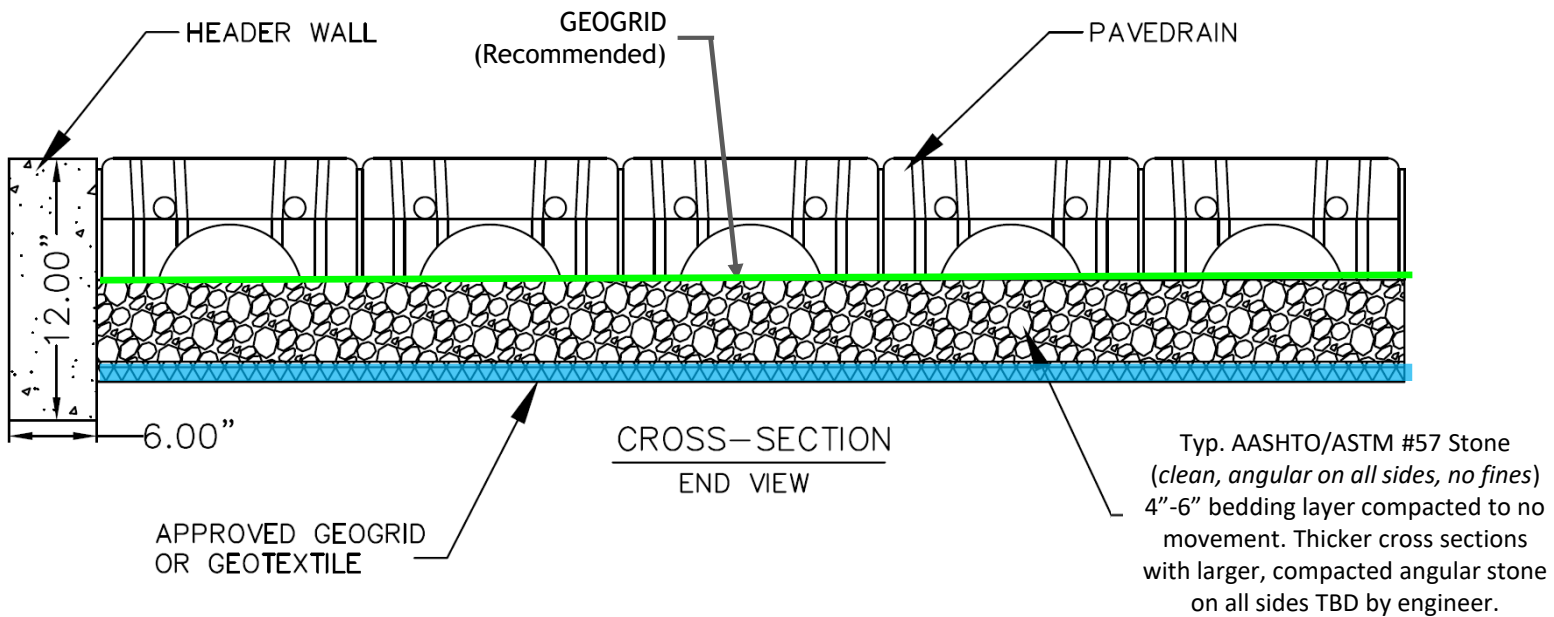

The **Two Stage Curb** detail below is an edge restraint solution that can be used when the PaveDrain System terminates on a curve or radius. The Two Stage Curb detail eliminates the need for field cutting of the PaveDrain blocks to match the required curve or radius.

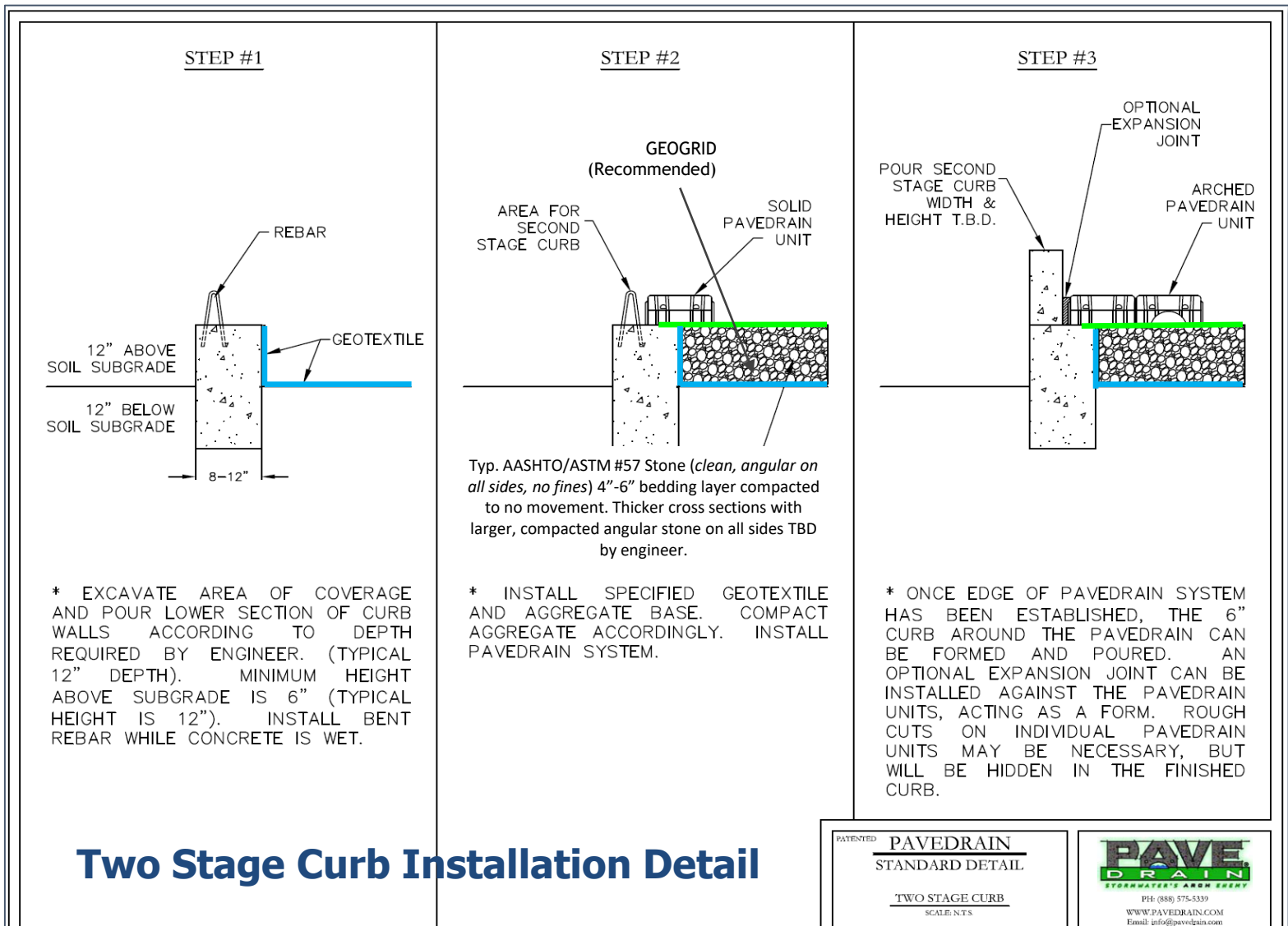



1. Minimal cutting of the PaveDrain blocks.
2. Compacted rock is brought to proper height.
3. Exposed rebar is for securing poured curb after the block are installed.

Two Stage Curb Photos



Curb is poured ON TOP of the PaveDrain.

Completed Two Stage Curbs



Section 4

PaveDrain End Block

The **PaveDrain End Block** is designed to give a smooth transition between the PaveDrain system and the existing surfaces. Installation of the End Block can be done in conjunction with all 3 types of installation methods used on the PaveDrain system.

Conventional materials, such as rock, 1/2" expansion board, asphalt or concrete, are easily placed directly between the PaveDrain® End Block and the existing structure.

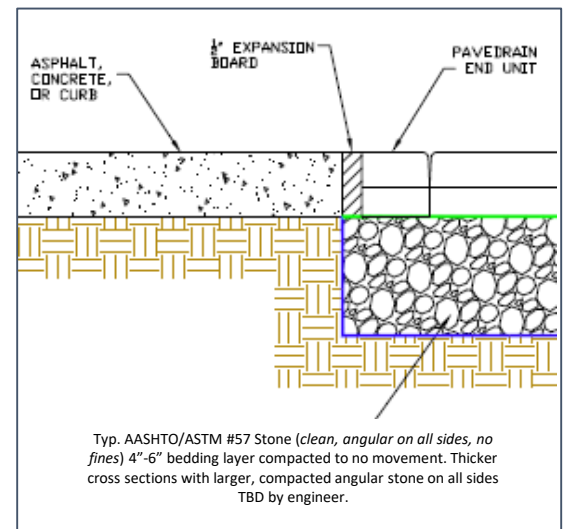
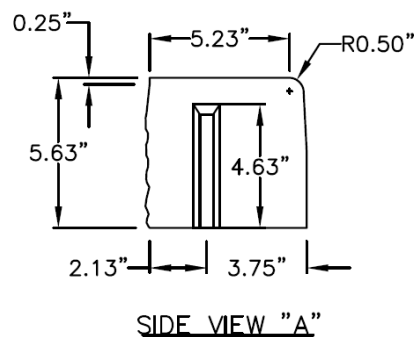

Section 5

Finishing the PaveDrain System

As always, the joints within the PaveDrain system are designed to be left open. Placing sand or small rock chips within the open joints is not recommended. Following the installation of the PaveDrain system, slight unevenness between the individual blocks may be evident. To resolve this, a (non-vibrating) double-drum roller or paver roller may be run over the top (see Fig. 18 & 19 below).

No individual PaveDrain unit shall protrude more than one-quarter (1/4) inch within the plane of the final placed blocks. No gap between the individual PaveDrain blocks or the surrounding Edge Restraint shall exceed one-half (1/2) inch.

Fig. 18



Fig. 19

