

GABION MAT GALVANIZED

Product Description

The gabion mat is a structure made of 8x10 hexagonal double twisted wire mesh type as per ASTM A975 (Fig. 2). They are filled with stones and closed using lids at the project site to form flexible, permeable, monolithic structures such as channel linings and scour aprons for erosion control projects.

The wire mesh used is heavily zinc coated soft temper steel. The zinc coating is applied to provide added protection against corrosion. The standard specifications of mesh-wire are shown in Table 1.

The gabion mats are divided into cells by means of diaphragms. Typically, cells are 3 ft (0.9 m) wide by 9 ft (2.8 m) long (Fig. 1). In order to reinforce the structure, all edges are selvedged with a wire of greater diameter (Table 3). Cells 3 ft (0.9 m) wide by 3 ft (0.9 m) long can be manufactured as per requirements.

Dimensions, tolerances and sizes of galvanized gabion mats are shown in Table 2.

Wire

All tests on wire must be performed prior to manufacturing the mesh. All wire should comply with ASTM A975, style 1 coating, galvanized steel wire. Wire used for the manufacture of gabion mats and the lacing wire, shall have a maximum tensile strength of 75 000 psi (515 MPa) as per ASTM A641, soft temper steel.

Woven Wire Mesh Type 8x10

The mesh and wire characteristics shall be in accordance with ASTM A975 Table 1, Mesh type 8x10. The nominal mesh opening, $D = 3.25$ inches (83 mm) as per Fig. 2.

The minimum mesh properties for strength and flexibility should be in accordance with the following:

- *Mesh Tensile Strength* shall be a minimum of 3500 lb/ft (5.1 kN/m) when tested in accordance with ASTM A975 section 13.1.1.
- *Punch Test* resistance shall be a minimum of 6000 lb (26.7 kN) when tested in compliance with ASTM A975 section 13.1.4.
- *Connection to Selvedges* shall be 1400 lb/ft (20.4 kN/m) when tested in accordance with ASTM A975.

Lacing, Assembly and Installation

Lacing operations to assemble and connect gabion mat units are made by using lacing wire specified in Table 3 and described in Fig. 3. Galvanized fasteners can be used instead of lacing wire (Fig. 4 and Fig. 5).

Galvanized rings for gabion mats shall be in accordance with ASTM A975 section 6.3.

Spacing of the rings shall be in accordance with ASTM A975 Table 2, Panel to Panel connection, Pull-Apart Resistance. In any case, ring fasteners spacing shall not exceed 6 in (150 mm) (Fig. 3).

The rings can be installed using pneumatic or manual tools (Fig. 5).

For full details, please see the Gabion Product Installation Guide.

The average maximum resistance of the fasteners from the field shall not be lower than 90% of the resistance provided in the certification.

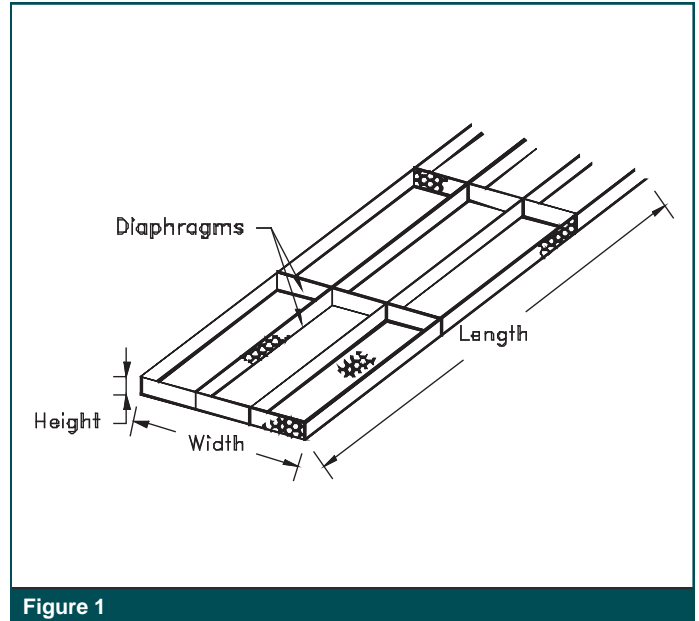

Figure 1

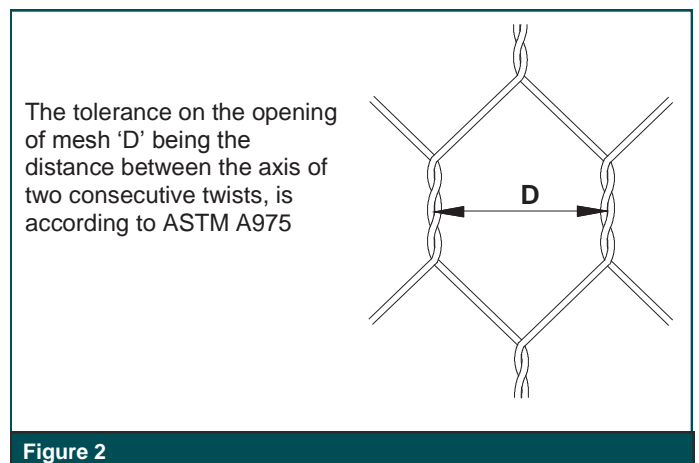

Figure 2

1. Table of sizes for gabion mats

L=Length ft (m)	W=Width ft (m)	H=Height ft (m)	# of cells
99 (30)	6 (1.9)	0.5 (0.15)	22
99 (30)	9 (2.8)	0.5 (0.15)	33
99 (30)	6 (1.9)	1 (0.3)	22
99 (30)	9 (2.8)	1 (0.3)	33
99 (30)	6 (1.9)	1.5 (0.45)	22
99 (30)	9 (2.8)	1.5 (0.45)	33
60 (19)	6 (1.9)	1 (0.3)	14
60 (19)	9 (2.8)	1 (0.3)	21
60 (19)	6 (1.9)	1.5 (0.45)	14
60 (19)	9 (2.8)	1.5 (0.45)	21

All sizes and dimensions are nominal. Tolerances of $\pm 5\%$ of the width, and length height, of the gabion mats shall be permitted.

2. Standard Mesh-Wire

Type	D in (mm)	Tolerance	Internal Wire Dia in (mm)
8x10/ZN	3.25 (83)	$\pm 10\%$	0.120 (3.05)

3. Standard wire diameters

	Lacing Wire	Mesh Wire	Selvedge Wire
Wire Mesh Diameter ϕ in. (mm)	0.087 (2.20)	0.120 (3.05)	0.153 (3.90)
Wire Tolerance (\pm) ϕ in. (mm)	0.004 (0.10)	0.004 (0.10)	0.004 (0.10)
Minimum Qty/Zinc oz/ft ² (g/m ²)	0.70 (214)	0.85 (259)	0.90 (275)

Quantity Request

When requesting a quotation, please specify:

- number of units,
- size of units (length x width x height, see Fig.1),
- type of mesh,
- type of coating.

EXAMPLE: No. 100 gabion mats, 99x6x1, Mesh type 8x10, Wire diameter 0.120 in (3.05 mm), Galvanized.

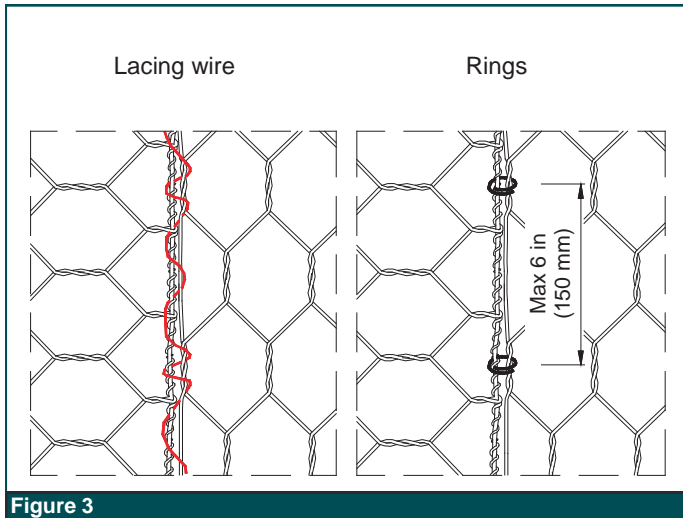

Figure 3

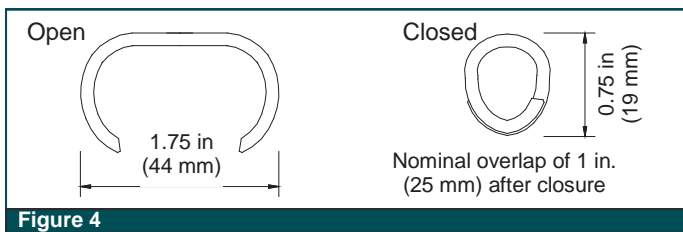

Figure 4

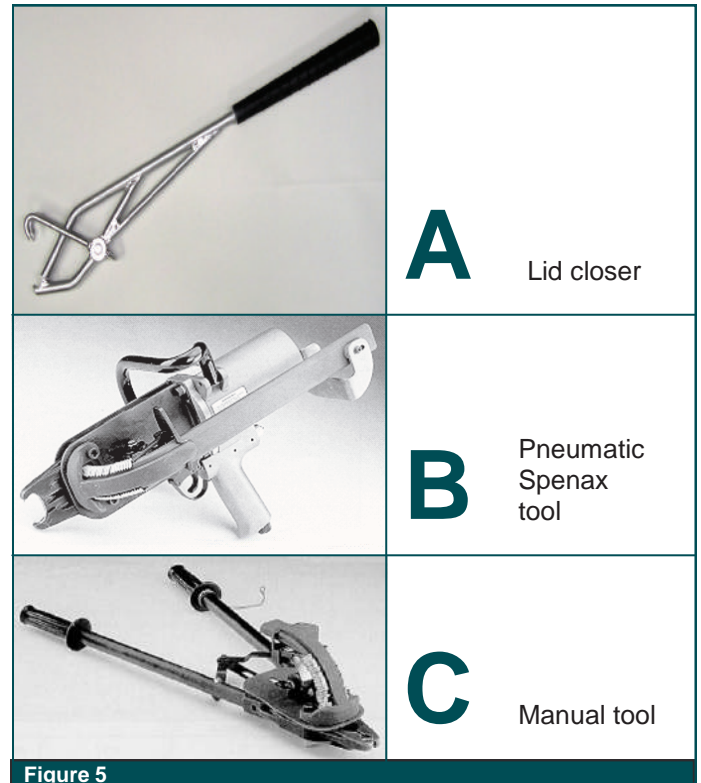

Figure 5